

()
INTERSTATE COUNCIL FOR STANDARDIZATION, METROLOGY AND CERTIFICATION
(ISC)

35326—
2025
(EN 12310-2:2018)

()

(EN 12310-2:2018, Flexible sheets for waterproofing — Determination of resistance to tearing — Part 2: Plastic and rubber sheets for roof waterproofing, MOD)

1.0 «
 1.2 «
 »
 1 ()
 5
 2 144 «
 »
 3 (28 2025 . 191-)
 :

(3166) 004—97	(3166) 004—97	
	BY KZ KG RU TJ UZ	« »

4 11
 2025 . 1694- 35326—2025 (EN 12310-2:2018)
 1 2026 .

5
 EN 12310-2:2018 «
 2.
 («Flexible sheets for waterproofing — Determination of resistance to tearing — Part 2: Plastic and rubber sheets for roof waterproofing, MOD)
 2 «
 7500-1, 9.2 «
 2 «
 1.5 (3.6).
 ,
 -

6

7

56583—2015 (EN 12310-2:2000)¹⁾

1694- 56583—2015 (EN 12310-2:2000) 1 2026 . 11 2025 .

()

,

,

-

,

-

,

«

»

©

.

«

», 2026



,

()

()

Roofing and hydraulic-insulating flexible polymeric (thermoplastic or elastomer) materials. Method for determination of resistance to tearing

— 2026—09—01

1

(—) ()

2

:

EN 13416

().

—

(www.easc.by)

3

3.1

:

4

5

(100 ± 10) /

2000
50

3

3

2

1

1.

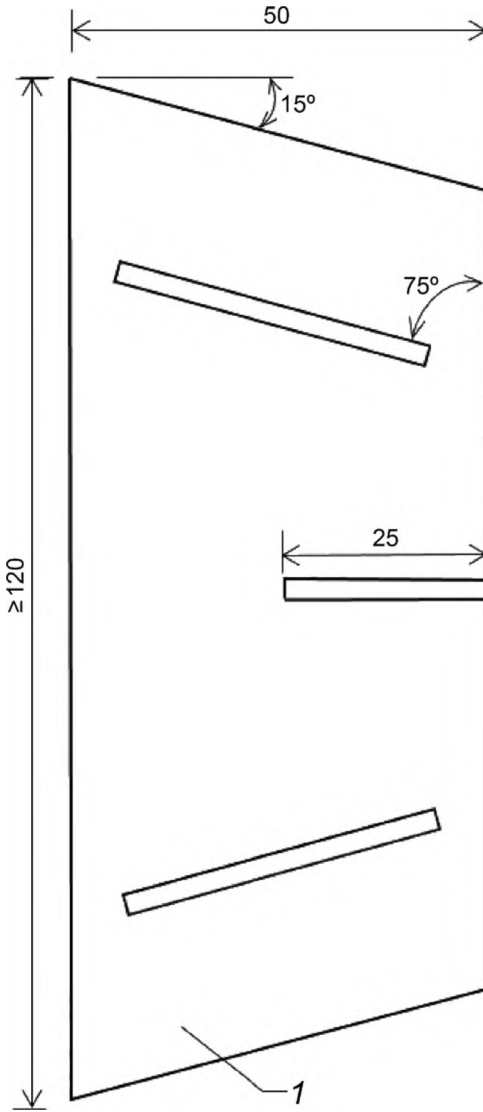

1—

2 3

1—

6

EN 13416.

7

2.

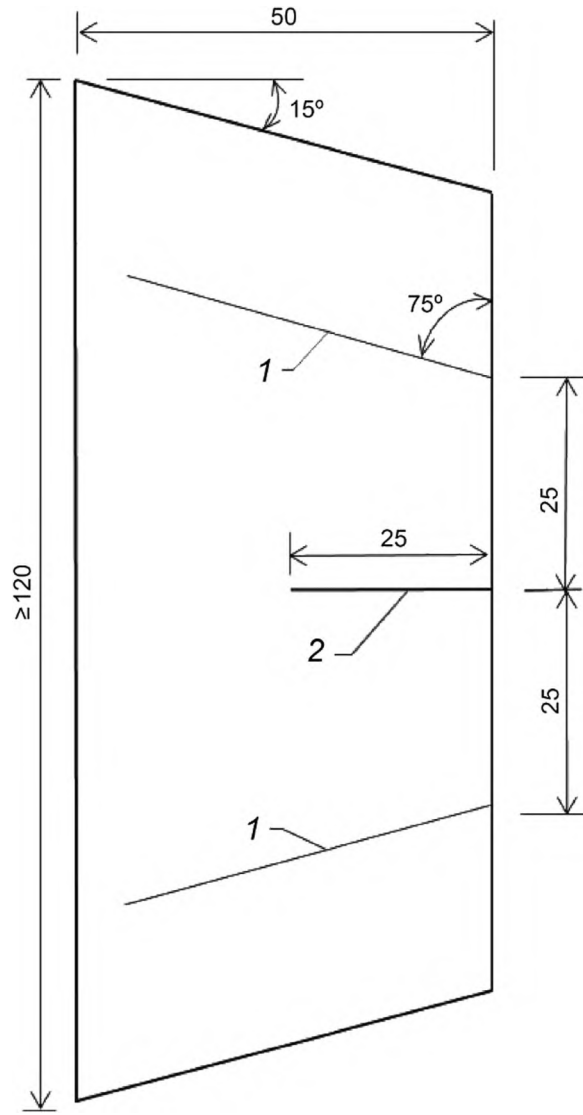

1— ; 2—
2—

1°.

(50 ± 5) %.

20

(23 ± 2) °C

8

5) , (. , 3).

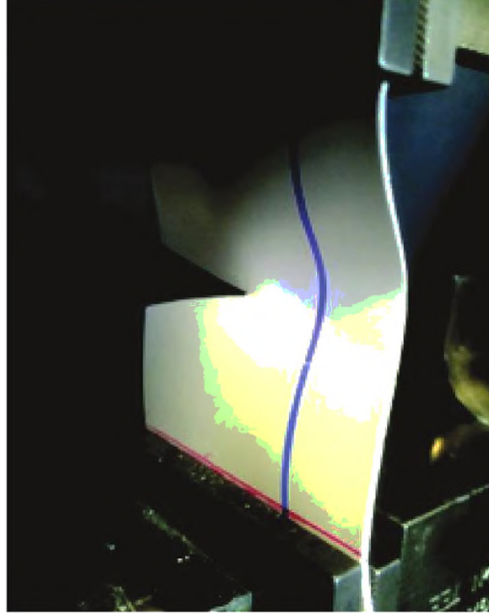

3—
(100 ± 10) / (23 ± 2) °C

9

10

) ;
) ;
) ;
d) 6; 7;
) 9;
f) ;
)

()

,

.1

TOCTEN 13416—2011	IDT	EN 13416:2001 « »
- IDT —		

35326—2025

692.415.001.4:006.354

91.100.50

MOD

:
)

(

16.12.2025.

20.01.2026.

60x847s.

. . . 1,40. .- . . 1,12.

«

»

117418 , - , .31, .2.
www.gostinfo.ru info@gostinfo.ru

