

Non-destructive testing — Penetrant testing —

Part 2: Testing of penetrant materials

无损检验——渗透检验

第 2 部分：渗透材料试验

The European Standard EN ISO 3452-2:2000 has the status of a
British Standard

ICS 19.100

National foreword

This British Standard is the official English language version of EN ISO 3452-2:2000. It is identical with ISO 3452-2:1999.

The UK participation in its preparation was entrusted to Technical Committee WEE/46, Non-destructive testing, which has the responsibility to:

- aid enquirers to understand the text;
- present to the responsible international/European committee any enquiries on the interpretation, or proposals for change, and keep the UK interests informed;
- monitor related international and European developments and promulgate them in the UK.

A list of organizations represented on this committee can be obtained on request to its secretary.

Cross-references

Attention is drawn to the fact that CEN and CENELEC Standards normally include an annex which lists normative references to international publications with their corresponding European publications. The British Standards which implement these international or European publications may be found in the BSI Standards Catalogue under the section entitled "International Standards Correspondence Index", or by using the "Find" facility of the BSI Standards Electronic Catalogue.

A British Standard does not purport to include all the necessary provisions of a contract. Users of British Standards are responsible for their correct application.

Compliance with a British Standard does not of itself confer immunity from legal obligations.

Summary of pages

This document comprises a front cover, an inside front cover, the EN title page, pages 2 to 27 and a back cover.

The BSI copyright notice displayed in this document indicates when the document was last issued.

This British Standard, having been prepared under the direction of the Engineering Sector Committee, was published under the authority of the Standards Committee and comes into effect on 15 June 2000

© BSI 06-2000

Amendments issued since publication

Amd. No.	Date	Comments

EUROPEAN STANDARD

EN ISO 3452-2

NORME EUROPÉENNE

EUROPÄISCHE NORM

April 2000

ICS 19.100

English version

Non-destructive testing - Penetrant testing - Part 2: Testing of penetrant materials (ISO 3452-2:2000)

Essais non destructifs - Examen par ressuage - Partie 2:
Essais des produits de ressuage (ISO 3452-2:2000)

Zerstörungsfreie Prüfung - Eindringprüfung - Teil 2: Prüfung
von Eindringprüfmitteln (ISO 3452-2:2000)

This European Standard was approved by CEN on 17 September 1999.

CEN members are bound to comply with the CEN/CENELEC Internal Regulations which stipulate the conditions for giving this European Standard the status of a national standard without any alteration. Up-to-date lists and bibliographical references concerning such national standards may be obtained on application to the Central Secretariat or to any CEN member.

This European Standard exists in three official versions (English, French, German). A version in any other language made by translation under the responsibility of a CEN member into its own language and notified to the Central Secretariat has the same status as the official versions.

CEN members are the national standards bodies of Austria, Belgium, Czech Republic, Denmark, Finland, France, Germany, Greece, Iceland, Ireland, Italy, Luxembourg, Netherlands, Norway, Portugal, Spain, Sweden, Switzerland and United Kingdom.



EUROPEAN COMMITTEE FOR STANDARDIZATION
COMITÉ EUROPÉEN DE NORMALISATION
EUROPÄISCHES KOMITEE FÜR NORMUNG

Central Secretariat: rue de Stassart, 36 B-1050 Brussels

Contents

	Page
Foreword	3
Introduction	3
1 Scope	4
2 Normative references	4
3 Definitions	4
4 Safety precautions	4
5 Classification	5
6 Testing of penetrant materials	5
7 Test methods and requirements	7
8 Packaging and labelling	15
Annex A (normative) Comparison of fluorescent brightness	16
Annex B (normative) Process control tests	17
Annex C (informative) Determination of fluorescent penetrant sensitivity levels	25
Annex D (informative) Example of indication visibility measuring equipment	26

Foreword

The text of EN ISO 3452-2:1999 has been prepared by Technical Committee CEN/TC 138 "Non-destructive testing", the secretariat of which is held by AFNOR, in collaboration with Technical Committee ISO/TC 135 "Non-destructive testing".

This European Standard shall be given the status of a national standard, either by publication of an identical text or by endorsement, at the latest by October 2000, and conflicting national standards shall be withdrawn at the latest by October 2000.

This European Standard has been prepared under a mandate given to CEN by the European Commission and the European Free Trade Association. This European Standard is considered to be a supporting standard to those application and product standards which in themselves support an essential safety requirement of a New Approach Directive and which make reference to this European Standard.

According to the CEN/CENELEC Internal Regulations, the national standards organizations of the following countries are bound to implement this European Standard: Austria, Belgium, Czech Republic, Denmark, Finland, France, Germany, Greece, Iceland, Ireland, Italy, Luxembourg, Netherlands, Norway, Portugal, Spain, Sweden, Switzerland and the United Kingdom.

EN ISO 3452 comprises a series of European standards of penetrant testing which is made of the following:

- *EN 571-1 Non-destructive testing - Penetrant testing - Part 1: General principles*
- *EN ISO 3452-2 Non-destructive testing - Penetrant testing - Part 2: Testing of penetrant materials*
- *EN ISO 3452-3 Non-destructive testing - Penetrant testing - Part 3: Reference test blocks*
- *EN ISO 3452-4 Non-destructive testing - Penetrant testing - Part 4: Equipment*

Introduction

At the present time, one part of this standard is published independently on the European and ISO levels, the others are under Vienna agreement and consequently have the ISO number at the European level. However, the Vienna agreement was applied during the work, so some European Standards have referenced them under their previous European number. The following table gives the correspondance between these different numbers.

	CEN Number	
	previous number *	official number
Non destructive testing - Penetrant testing		
Part 1: General principles		EN 571-1
Part 2: Testing of penetrant materials	prEN 571-2	EN ISO 3452-2
Part 3: Reference test blocks	prEN 571-3	EN ISO 3452-3
Part 4: Equipment	prEN 956	EN ISO 3452-4
* Number under which the document is referenced in some European Standards		

1 Scope

This European Standard specifies the technical requirements and test procedures for penetrant materials for their type testing and batch testing. It also details on site testing requirements and methods.

2 Normative references

This European Standard incorporates by dated or undated references, provisions from other publications. These normative references are cited at the appropriate places in the text and the publications are listed hereafter. For dated references subsequent amendments to, or revisions of any of these publications apply to this European Standard only when incorporated in it by amendment or revisions. For undated reference the latest edition of the publication referred to applies.

EN 473, *Qualification and certification of NDT personnel - General principles.*

EN 571-1, *Non-destructive testing - Penetrant testing - Part 1: General principles.*

EN 10204, *Metallic products - Types of inspection documents.*

prEN ISO 3059, *Non-destructive testing - Penetrant testing and magnetic particle testing - Viewing conditions.*

EN ISO 3452-3, *Non-destructive testing - Penetrant testing - Part 3: Reference test blocks.* (ISO 3452-3:1998)

EN ISO 12706, *Non-destructive testing - Terminology - Terms used in penetrant testing.* (ISO 12706:1999)

3 Definitions

For the purpose of this standard the definitions of EN ISO 12706 and the following definition apply:

batch

quantity of material produced at one operation having uniform properties throughout and with a unique identifying number of mark.

4 Safety precautions

The materials required by this standard include chemicals which may be harmful, flammable and/or volatile. All necessary precautions shall be observed. All relevant European, national and local regulations pertaining to health and safety, environmental requirements, etc. shall be observed.

5 Classification

Penetrant testing materials covered by this specification shall be classified as follows:

5.1 Testing products

The testing products are classified according to table 1:

Table 1 - Testing products

Penetrant		Excess penetrant remover		Developer	
Type	Denomination	Method	Denomination	Form	Denomination
I	Fluorescent penetrant	A	Water	a	Dry
II	Colour contrast penetrant	B	Lipophilic emulsifier 1 Oil-based emulsifier 2 Rinsing with running water	b	Water soluble
				c	Water suspendable
III	Dual purpose (fluorescent colour contrast penetrant)	C	Solvent (liquid)	d	Solvent-based (non-aqueous wet)
		D	Hydrophilic emulsifier 1 optional prerinse (water) 2 emulsifier (water-diluted) 3 final rinse (water)	e	Water or solvent based for special application (e. g. peelable developer)
		E	Water and solvent		

5.2 Sensitivity levels

5.2.1 Fluorescent product family

Sensitivity level 1 (normal)
Sensitivity level 2 (high sensitivity)
Sensitivity level 3 (ultra high for specialised uses)

5.2.2 Colour contrast product family

Sensitivity level 1 (normal)
Sensitivity level 2 (high sensitivity).

5.2.3 Dual purpose product family

There are no specific sensitivity levels for dual purpose penetrants. Classification can be carried out as for colour contrast systems.

6 Testing of penetrant materials

6.1 Testing facilities

6.1.1 Type testing

Type testing shall be carried out on penetrant materials according to EN 571-1 to ensure their conformance to the requirements of this European Standard. The test shall be carried out by an independent laboratory.

6.1.2 Batch testing

Batch testing to the requirements of this European Standard shall be carried out on each production batch according to EN 571-1 to ensure that, where applicable, it has the same properties as its corresponding type approval sample. In case of penetrant material packed in spray cans, the content of sulfur and halogens shall be additionally determined according to 7.12.

6.1.3 Process control testing

Process control testing shall be carried out or commissioned by the user in accordance with the requirements of EN 571-1, EN ISO 3452-2 and EN ISO 3452-3.

6.2 Reporting

6.2.1 Type testing

The independent laboratory (see 6.1.1) shall provide a certificate of compliance with this standard and a report that details the result obtained.

If any changes are made to the penetrant material composition then a new type test and product identity shall be required.

6.2.2 Batch testing

The manufacturer of the penetrant materials shall provide a certificate of compliance with this standard, e. g. as specified in EN 10204.

6.2.3 Process control testing

Results obtained shall be recorded (see Annex B).

6.3 Required tests

6.3.1 Penetrants

Type and/or batch testing shall be carried out for the properties of penetrants using the test methods according to table 2.

Table 2 - Properties of penetrants and required tests

Property	Test	Test method according to clause
Appearance	Batch	7.1
Sensitivity	Type and batch	7.2
Density	Type and batch	7.3
Viscosity	Type and batch	7.4
Flash point	Type and batch	7.5
Penetrant washability (method A penetrants only)	Batch	7.6
Fluorescent brightness (type I penetrants)	Batch	7.7
UV stability (type I penetrants)	Type	7.8
Thermal stability (type I penetrants)	Type	7.9
Water tolerance (method A penetrants only)	Type	7.10
Corrosive properties	Type and batch	7.11
Content of sulfur and halogens*)	Type and batch	7.12
Other contaminants on request (as required)	Batch	

*) Only required for products designated "Low in sulfur and halogens"

6.3.2 Excess penetrant removers (excluding method A)

Type and/or batch testing shall be carried out for the properties of excess penetrant removers using the test methods according to table 3.

Table 3 - Properties of excess penetrant removers and required tests

Property	Test	Test method according to clause
Appearance	Batch	7.1
Sensitivity	Type and batch	7.2
Density	Type and batch	7.3
Viscosity (for method B and D only)	Type and batch	7.4
Flash point	Type and batch	7.5
Water tolerance (method B only)	Type and batch	7.10
Corrosive properties	Type and batch	7.11
Content of sulfur and halogens*)	Type and batch	7.12
Residue on evaporation (method C and E only)	Type and batch	7.13
Penetrant tolerance (method B and D only)	Type	7.14
Other contaminants on request (as required)	Batch	
*) Only required for products designated "Low in sulfur and halogens"		

6.3.3 Developers

Type and/or batch testing shall be carried out for the properties of developers using the test methods according to table 4.

Table 4 - Properties of developers and required tests

Property	Test	Test method according to clause
Appearance	Batch	7.1
Flash point (form d only)	Type and batch	7.5
Corrosive properties (except form a)	Type and batch	7.11
Content of sulfur and halogens*)	Type and batch	7.12
Solid content (form d only)	Type and batch	7.13
Developer performance (except form e)	Type and batch	7.15
Re-dispersibility (form c and d only)	Type and batch	7.16
Density (of carrier liquid) (form d only)	Type and batch	7.17
Other contaminants on request (as required)	Batch	
*) Only required for products designated "Low in sulfur and halogens"		

6.3.4 Batch control tests for pressurised containers

Batch control testing shall be carried out using the following test:

Product performance, see 7.18

The first aerosol container of each batch shall be tested.

7 Test methods and requirements**7.1 Appearance**

The appearance of the sample shall be the same as that of the type test material.

7.2 Penetrant system sensitivity

See also Annex C.

7.2.1 Fluorescent penetrants

7.2.1.1 Test panels

Test panels of 10 μm , 20 μm and 30 μm from type 1 reference block in accordance with EN ISO 3452-3 are used. These test panels shall be reserved for the use with type I penetrants only.

7.2.1.2 Apparatus

The measurement of the visibility of indications is made electronically.

A visibility measuring equipment consists for example of the following elements (see Annex D):

- microscope assembly,
- test panel holder and moving table,
- recording system,
- suitable source of illumination,
- instrument calibration test piece.

7.2.1.3 Calibration

The visibility measuring equipment shall be calibrated using a calibration test piece consisting of a polished metal plate, approximately 33 mm x 95 mm which has transverse grooves across its width.

The groove length should be longer than 20 mm, the groove width should be 0,15 mm \pm 0,015 mm and the depth should be greater than 1 mm. These grooves are to be filled with a suitable powder.¹⁾

The test piece shall be used to calibrate visibility measurement equipment, the height of the peak on the chart recorder caused by the powder in the groove being taken as 100 % when used according to 7.2.1.4.

7.2.1.4 Method

For each test panel the number of discontinuities shall be counted using a microscope with a 20 times magnification.

As photomultipliers are sensitive to temperature, light and magnetic field changes, they should therefore be protected as required. Allow the equipment to stabilise prior to use.

The equipment shall be set up using a standard fluorescence sample (see D.4) to give approximately a 50 % full scale deflection. The zero shall be adjusted to read zero with an unprocessed test panel from type 1 reference block.

The test panel of 30 μm depth from type 1 reference block shall be processed in accordance with the penetrant manufacturer's recommendations using a form d developer and a 10 minute development time. The brightness of the indications is quantified using the discontinuity intensity measuring equipment.

If it is necessary to change sensitivity ranges on a chart recorder between setting up with the standard sample and running the test panel, zero and full scale deflection settings shall remain unaltered. In such cases standard peak height and sample peak heights shall be compared taking the different chart recorder sensitivities into consideration.

7.2.1.5 Interpretation of results

The visibility measuring equipment having been set up according to 7.2.1.3, ("A" on figure 1), the base is taken as 0 % ("B" on figure 1). Individual peak heights are recorded except those affected by handling, etc. Grouped peaks ("C" on figure 1) are recorded as their mean value.

The mean peak height (\bar{x}) and standard deviation of the peak height (σ_{n-1}) are determined and the sensitivity level is then obtained by reference to figure 2.

¹⁾ KEMK 63/M is an example of a suitable product available commercially from Phosphor Technology Ltd. Middle Stray, Nazing, Essex, EN9 2LP, U. K. This information is given for the convenience of users of this standard and does not constitute an endorsement by CEN of the product named.

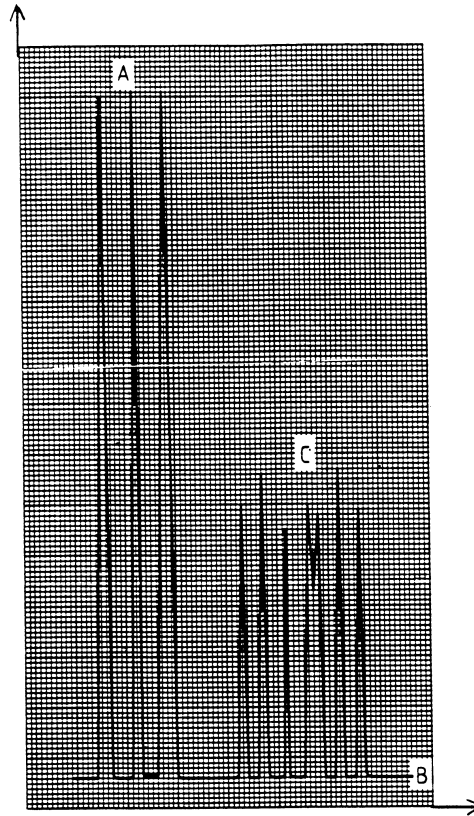

for this example
 $\bar{x} = 41,8$ % of standard calibration level
 $\sigma_{n-1} = 8,54$ % of \bar{x}

Figure 1 - Example of trace from an indication visibility measuring equipment

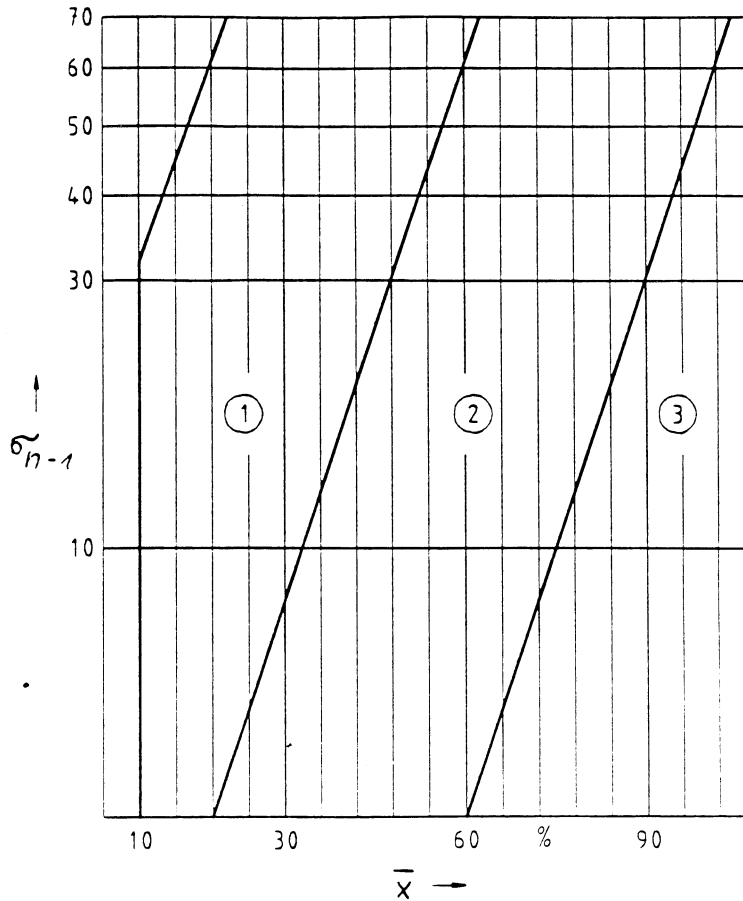

- 1 Sensitivity level 1
- 2 Sensitivity level 2
- 3 Sensitivity level 3

Figure 2 - Criteria for sensitivity levels

7.2.2 Colour contrast penetrants

7.2.2.1 Test panels

Test panels of 30 μm and 50 μm from type 1 reference block. Test panels shall be reserved for the use with type II penetrants only.

7.2.2.2 Method of use

The panels shall be processed according to the penetrant manufacturer's recommendation using a form d developer and 10 min development time.

7.2.2.3 Interpretation of results

The number of unbroken indications covering at least 80 % of the panel width clearly visible to the unaided eye (with glasses if usually worn) shall be counted and compared with the number known to be achievable with the same test block. (Number achievable is the number found when the block is first tested using a level 3 fluorescent penetrant used in accordance with manufacturer's recommendations and inspected as per EN 571-1 after which the panels are subjected to a complete cleaning).

7.2.2.4 Requirements

Sensitivity level shall be determined by reference to table 5.

Table 5 - Determination of sensitivity level for colour contrast penetrants

Sensitivity level	% of discontinuities found	
	30 μm	50 μm
1	-	> 90
2	75	100

7.3 Density

7.3.1 Test method

Density at 20 °C shall be determined by use of a method with an accuracy of better than $\pm 1\%$.

7.3.2 Requirements

This result shall be reported for type testing (nominal value). For batch testing a tolerance of $\pm 5\%$ shall be permitted on the nominal value.

7.4 Viscosity

7.4.1 Test method

Viscosity shall be determined by a suitable method with an accuracy of better than $\pm 1\%$. The result shall be recorded at the temperature used for the type test.

7.4.2 Requirements

This result shall be reported for type testing (nominal value). For batch testing a tolerance of $\pm 10\%$ on the nominal value shall be permitted.

7.5 Flashpoint

7.5.1 Test method

Flashpoint shall be determined by an appropriate stated method with an accuracy of better than $\pm 2\text{ °C}$ for materials with a flashpoint smaller than 100 °C or better than $\pm 5\text{ °C}$ for materials with a flashpoint greater than or equal to 100 °C.

Attention is drawn to the hazards involved in testing materials with flashpoints below 25 °C.

For batch testing, flashpoint measurement shall only be required if the expected flashpoint is within the range 20 °C to 110 °C. The flashpoint shall be determined by an appropriate method.

7.5.2 Requirements

The result shall be reported for type testing (nominal value). The flashpoint for batch testing shall not be more than 5 °C below the nominal value.

7.6 Washability (method A penetrants)

When removed with a gentle water spray at $20\text{ °C} \pm 5\text{ °C}$ the sample penetrant shall not leave more residue on the reference test block type 2 for surface roughness areas with $R_a = 5\ \mu\text{m}$ and $R_a = 10\ \mu\text{m}$ than the type test sample of the same penetrant rinsed under identical conditions. For fluorescent penetrants this test shall be carried out under UV-A irradiance in excess of 3 W/m².

7.7 Fluorescent brightness

7.7.1 Test method

Fluorescent brightness shall be determined in accordance with annex A using the type test sample of penetrant as standard.

7.7.2 Requirements

The fluorescent brightness shall be at least 90 % of the type test sample.

7.8 UV stability

7.8.1 Test method

10 filter paper specimens are prepared with the test penetrant and the method detailed in A.2. Five of them are protected from heat, light and air currents, while the other 5 specimens are exposed to UV-A irradiation (365 nm) of $10 \text{ W/m}^2 \pm 1 \text{ W/m}^2$ whilst being protected from heat and air currents for 1 hour. The fluorescent brightness of each specimen is determined as per the method in A.3.

7.8.2 Requirements

The average fluorescent brightness of the UV-A irradiated specimens shall be greater than 80 % of the non-irradiated specimens.

7.9 Thermal stability of the fluorescent brightness

7.9.1 Test method

10 filter paper specimens are prepared with the test penetrant and the method detailed in A.2. 5 of them are protected from heat, light and air currents, while the other 5 specimens are placed on a clean metal plate in a dead air oven at $115 \text{ °C} \pm 2 \text{ °C}$ for 1 hour. The fluorescent brightness of each specimen is determined as per the method in A.3.

7.9.2 Requirements

The average fluorescent brightness of the heated specimens shall be greater than 80 % of the unheated specimens.

7.10 Water tolerance

7.10.1 Test method

The water tolerance shall be determined by adding water accurately to a constantly stirred, accurately measured quantity of test material (typically 20 ml) until test material turns cloudy, thickens or separates. This test shall be carried out at $15 \text{ °C} \pm 0,5 \text{ °C}$.

Water tolerance is the percentage of added water in the final volume (water and test material at which cloudiness/-thickening occurred).

7.10.2 Requirements

The water tolerance shall be greater than 5 %.

7.11 Corrosive properties

The compatibility of the penetrant material and the materials to be inspected shall be confirmed by the following methods.

7.11.1 Type testing

7.11.1.1 Compatibility with metals

For penetrant materials intended for use on metallic components the test shall be carried out on bare 7075-T6 aluminium alloy, or equivalent, AZ-31B magnesium alloy, or equivalent, and 30CrMo4 steel, or equivalent. Test panels of each of these materials on a prepared surface that has been polished with silicon carbide paper (240 grit) and then rinsed with a volatile, sulfur-free hydrocarbon solvent (e. g. analytical grade acetone), immediately prior to use.

The test panels shall be immersed to half their length in the penetrant material under test, placed in a glass beaker of sufficient size, inside a Parr bomb calorimeter (or equivalent container capable of withstanding an internal pressure of 700 kPa) as described in figure 3.

The sealed calorimeter is then placed in an oven, or hot water bath, maintained at $50 \text{ °C} \pm 1 \text{ °C}$ for 2 hours ± 5 min. At the end of which time the test panel is removed and rinsed briefly under distilled water or organic solvent, as appropriate, to remove all residues of penetrant materials. The test panel shall then be inspected.

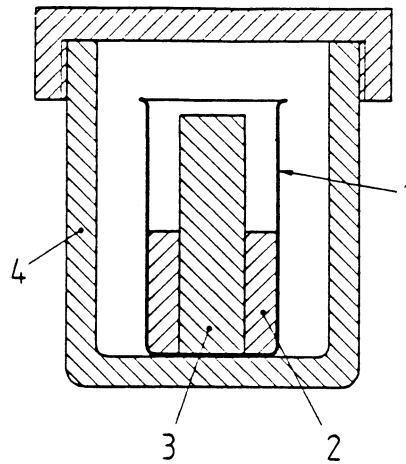

- 1 Beaker
- 2 Penetrant material
- 3 Test panel
- 4 Calorimeter

Figure 3 - Parr bomb calorimeter

7.11.1.1.1 Requirements

There shall be no evidence of staining, pitting or any other corrosion when examined under X 10 magnification.

7.11.1.2 Compatibility with other materials

The procedure employed in 7.11.1.1 may be adapted for use with any other materials with which the penetrant material is to be used, by replacing the metal test panel with a panel of the other material.

7.11.1.2.1 Requirements

There shall be no evidence of degradation of the material under test.

7.11.2 Batch testing

7.11.2.1 Compatibility with metals

For penetrant materials intended for use on metallic components, test panels of the materials specified in 7.11.1.1 shall be prepared as described in that section. These panels shall then be immersed to half of their length in the penetrant material under test in a glass beaker. The panels shall be left for a period of 24 hours at room temperature after which time they shall be cleaned and inspected as per 7.11.1.1.

7.11.2.1.1 Requirements

There shall be no evidence of staining, pitting or any other corrosion.

7.11.2.2 Compatibility with other materials

The procedure employed in 7.11.1.1 may be adapted for use with any other materials with which the penetrant material is to be used, by replacing the metal test panel with a panel of the other material.

7.11.2.2.1 Requirements

There shall be no evidence of degradation of the material under test.

7.12 Content of sulfur and halogens (for products designated low in sulfur and halogens)

7.12.1 Test method

The content of sulfur and halogens shall be determined by a suitable stated method which has been shown to be accurate to $\pm 10 \cdot 10^{-6}$ at $< 200 \cdot 10^{-6}$ sulfur/halogens for liquids and $\pm 50 \cdot 10^{-6}$ for solids.

In the case of products conditioned in a spray can, purge the latter for 5 s before sampling and, at the moment of weighing, spray the content of the can into a 100 ml beaker, then pour immediately the product into the platinum boat. The operation shall not last more than 2 min between the start of sampling and the closing of the bomb calorimeter.

7.12.2 Requirements

Total sulfur content shall be less than 200×10^{-6} . Total halogen content (chloride and fluoride), without evaporation, shall be less than 200×10^{-6} .

7.13 Residue on evaporation/solid content

7.13.1 Solvent removers

A sample having an initial volume of $100 \text{ ml} \pm 1 \text{ ml}$ shall be evaporated for one hour on a $15 \text{ cm} \pm 1 \text{ cm}$ Petri dish on a water bath or oven at a temperature of $15 \text{ }^\circ\text{C} \pm 1 \text{ }^\circ\text{C}$ above final boiling point of the product. After this time the mass of the residue shall be measured.

7.13.1.1 Requirements

The mass shall be less than 5 mg.

7.13.2 Form d developers

A sample having an initial mass of $100 \text{ g} \pm 1 \text{ g}$ shall be evaporated for one hour on a $15 \text{ cm} \pm 1 \text{ cm}$ Petri dish on a water bath or oven at a temperature of $15 \text{ }^\circ\text{C} \pm 1 \text{ }^\circ\text{C}$ above final boiling point of the product. After this time the mass of the residue shall be measured and recorded as a percentage of the initial mass.

7.13.2.1 Requirements

The result shall be reported for type testing (nominal value). For batch testing a tolerance of $\pm 10 \%$ on the nominal value shall be permitted.

7.14 Penetrant tolerance

7.14.1 Lipophilic emulsifier (Method B)

The addition of 20 % (v/v) of the penetrant(s), with which the emulsifier is to be used, shall not result in an increase in the background found when the penetrant and emulsifier are used in accordance with the manufacturer's recommendations.

7.14.2 Hydrophilic emulsifier (Method D)

At the qualification concentration of the emulsifier the addition of 1 % (v/v) of the penetrant(s), with which the remover is certified, shall not result in an increase in the background found when the penetrant and emulsifier are used in accordance with the manufacturer's recommendations.

7.15 Developer performance

When applied according to manufacturer's recommendations, the developer shall give a fine, even, non-reflective and non-fluorescent coating.

When used in conjunction with the appropriate penetrant, the developer shall increase the visibility of the penetrant indications.

7.16 Re-dispersibility

7.16.1 Water suspendable developers

The solids shall be readily suspended when stirred or agitated.

7.16.2 Solvent based developers (non aqueous)

The solids shall be readily dispersed when stirred or agitated. Aerosol solids contents shall be suspended after 30 s of shaking.

7.17 Density of carrier liquid

7.17.1 Test method

The density of the carrier liquid shall be determined by a method with an accuracy of better than $\pm 1\%$.

7.17.2 Requirements

For type testing the result shall be reported (nominal value). For batch testing a tolerance of $\pm 5\%$ on the nominal value shall be permitted.

7.18 Product performance (pressurised containers)

When used in accordance with the manufacturer's recommendations, the product sprayed from the pressurised container shall satisfy the requirements of the normal batch production and the requirement of 7.12.

8 Packaging and labelling

Packaging and labelling shall be in accordance with all applicable international, national and local regulations. Containers and their contents shall be compatible. Containers shall be marked with batch number in order to ensure the traceability with the relevant documentation and the use-by date.

Annex A (normative)

Comparison of fluorescent brightness

A.1 Equipment

A.1.1 A fluorimeter having the following characteristics shall be used:

- Excitation wavelength: 365 nm \pm 20 nm
- Emitted light measured at 550 nm \pm 25 nm

The fluorimeter shall be equipped to hold filter paper samples (see A.2) and have a lightproof inside a sample compartment.

A.1.2 Glassware

Pipettes and measuring cylinders (volumetric flasks) suitable for accurately preparing 1,0 % solutions. 50 ml beakers.

A.1.3 Suitable absorbent, non fluorescent filter paper, for example Whatman (R) No. 4²⁾. Cut to 2 cm x 2 cm or as required to fit fluorimeter. These papers shall be kept dry in a dessiccator until use.

A.1.4 Filter paper drying stand "Crocodile" clips or similar to hold paper specimens vertically by the edge/corners.

A.1.5 Dessiccator suitable for holding the filter paper described in A.1.4.

A.1.6 Dessiccant

Suitable dessiccant, e. g. silica gel for use in the dessiccator as described in A.1.5.

A.1.7 Solvent

A fast drying, 100 % volatile, non fluorescent, dry, solvent fully miscible with the penetrant under test.

A.2 Preparation of filter paper specimens

A.2.1 Accurately prepare separate 1,0 % v/v solutions of test and standard penetrants in an appropriate solvent.

A.2.2 Pour each solution into a separate glass beaker and into each, place, one at a time, 5 filter paper specimens for 5 seconds each.

A.2.3 Allow each paper specimen to dry (approx. 5 minutes) by suspending them vertically in the "Crocodile" clips or similar in the dessiccator.

A.3 Measurement of fluorescent brightness

After allowing the fluorimeter to stabilise, zero the instrument and then introduce the filter paper specimens, one at a time, into the sample holder. Close the lightproof cover and measure intensity of the emitted light when the specimen is illuminated in the fluorimeter.

A.4 Calculation

A.4.1 Calculate the average reading given by the 5 standard specimens (S).

A.4.2 Calculate the average reading given by the 5 test specimens (T).

A.4.3 Fluorescent brightness of sample under test = $T/S \times 100 \%$

²⁾ Whatman (R) No. 4 is an example of a suitable product available commercially. This information is given for the convenience of users of this standard and does not constitute an endorsement by CEN of the product named.

Annex B
(normative)**Process control tests****B.1 General**

These process control tests are to be used when testing is carried out in accordance with EN 571-1.

In order to maintain the integrity of a penetrant process, the process as a whole and the individual components of the system shall be regularly checked to ensure that they meet the required standards. This requirement is only applicable to process lines since products supplied in aerosols or thixotropic penetrants will only be used for a single inspection. In addition some materials used in process lines can be applied to the work piece either by conventional or electrostatic spraying. Since once again the material will only be used for one inspection these tests are not applicable.

NOTE Where some elements of the process are sprayed it does not eliminate the need for control checks on other parts of the process.

B.2 Control tests

The following table details the control tests to be carried out and their frequency. It is the responsibility of a level 3 person according to EN 473 to decide which tests are applicable to a particular process line. The tests may be carried out at more frequent intervals or additional tests carried out if necessary to ensure correct processing conditions.

Table B.1 - Control test

SYSTEM PERFORMANCE FORM									
Control tests	According to clause	Frequency					Recording		
		Start of each work period	Weekly	Monthly	Every 12 months	Other	Numerical value	Visual assessment (Signature)	
System Review Materials levels (including spraying systems network)	B.4.1	X						Not applicable	
System performance using reference test block type 2	B.4.2	X						Not applicable	
General Review									
Penetrant appearance	B.4.3	X						Not applicable	
Rinse water appearance	B.4.4	X						Not applicable	
Rinse water temperature	B.4.5	X							Not applicable
Oven temperature	B.4.6	X							Not applicable
Working area	B.4.7	X						Not applicable	

Table B.1 - continued

	According to clause	Frequency						Recording	
		Start of each work period	Weekly	Monthly	Every 12 months	Other	Numerical Value	Visual assessment (Signature)	
Control tests									
Compressed air filter	B.4.8		X					Not applicable	
Integrity of UV-A filters (fluorescent system)	B.4.9	X						Not applicable	
UV-A irradiance (fluorescent system)	B.4.10			X					Not applicable
Visible light intensity in inspection booth (fluorescent systems)	B.4.11			X					Not applicable
Visible light intensity (colour contrast systems)	B.4.12			X					Not applicable
<u>Penetrants</u>									
Fluorescent intensity ¹⁾	B.4.13			X				Not applicable	
Colour contrast intensity ¹⁾	B.4.14			X				Not applicable	
Suppliers' overcheck	B.4.15				X			Not applicable	
<u>Emulsifiers</u>									
Concentration of freshly diluted hydrophilic remover	B.4.16						X		Not applicable

¹⁾ Not applicable for aerosols

Table B.1 - end

	According to clause	Frequency					Recording	
		Start of each work period	Weekly	Monthly	Every 12 months	Other	Numerical value	Visual assessment (Signature)
Control tests								
<u>Developers</u>								
Appearance of dry powder	B.4.17.1	X					Not applicable	
Fluorescence of dry powder	B.4.17.2	X						Not applicable
Water soluble developer								
a) Concentration	B.4.17.3.1	X						Not applicable
b) Wetting test	B.4.17.3.2	X						Not applicable
c) Temperature	B.4.17.3.3	X						Not applicable
d) Fluorescence of solution	B.4.17.3.4	X					Not applicable	
Water suspendible developer								
a) Concentration	B.4.17.4.1	X						Not applicable
b) Temperature	B.4.17.4.2	X						Not applicable
c) Fluorescence of suspension	B.4.17.4.3	X					Not applicable	
<u>Calibration</u>								
UV-A radiometer	B.4.18						Not applicable	
							≤ 24 months	
<u>Calibration</u>								
luxmeter	B.4.19						Not applicable	
							≤ 24 months	
<u>Calibration</u>								
thermometers	B.4.20					X	Not applicable	
<u>Pressure gauges</u>								
	B.4.21					X	Not applicable	Not applicable

B.3 Control test forms

The results of each control test shall be recorded on a control test form. A separate form shall be used for each penetrant plant. Any deviations found shall be reported to the responsible person and appropriate corrective action must be taken.

The following information shall be included:

- company and site,
- process line identity,
- date,
- shift,
- name and qualification,
- signature.

B.4 Control test

B.4.1 Materials levels

The level of material in all process systems shall be visually examined to ensure that there is sufficient material to allow complete coverage of the components to be processed. If insufficient material is in the system, extra material shall be added and mixed before any other tests are carried out.

B.4.2 System performance

This test is carried out using the reference test block type 2 described in EN ISO 3452-3. It is often advantageous to also use a component with known discontinuities typical of those normally expected.

A record in the form of a permanent replica, photograph or other suitable means showing the discontinuities including the level of background, shall be prepared and processed using the same parameters normally in use and retained for reference. This record shall be used as a comparison for the practical results obtained using the same test for the daily system performance check. Indications from peelable developers are not the same as obtained using standard developers. The indications on the chrome plated side of the reference test block type 2 or on the component with known discontinuities shall show the same number of indications and pattern with those of the record prepared using the same materials and process sequence. Similarly the level of background shall appear the same as that shown on the record.

B.4.2.1 Reference test parts cleaning

To ensure that reference test parts are sensitive enough to a change in penetrant process parameters, it is necessary to draw out all of the penetrant which remains entrapped in the discontinuities after testing. It is of the utmost importance not to physically modify the discontinuities.

The best way is to counteract adsorption effect on the entrapped penetrant due to the discontinuity walls by a stronger capillary effect. A solvent-based (non-aqueous wet) developer is the right means.

The following procedure shall be used:

- a) immediately after processing, remove developer with a water rinse;
- b) dry, i. e. not by wiping;
- c) apply a thick coat of form d developer. The coating shall arrive wet on the surface;
- d) leave for 10 to 15 minutes;
- e) repeat stages a) to d), let developer remain for 30 minutes;
- f) check for penetrant traces under adequate illumination. If present, repeat stages a) to d) until all traces of penetrant have been removed;
- g) finally wash with water and dry.
- h) do **not** keep parts in solvent. Parts may be stored in a protective envelop to prevent scratching, twisting, any mechanical or thermal shock.

B.4.3 Penetrant appearance

Check for any abnormal aspects of the penetrant (e.g. milky appearance, visible contamination, deposits of water at the bottom or top of the penetrant).

B.4.4 Rinse water appearance

When using re-cycled water, check for opacity, fluorescence, foam and colouration of the rinse water. Any of these suggests that the treatment system is not functioning effectively.

B.4.5 Rinse water temperature

Check that the rinse water temperature is within the specified limits.

B.4.6 Oven temperature

Check that the oven temperature is within the specified limits in the area of the work pieces.

B.4.7 Working area

Ensure that the working area is clean and tidy. When inspecting components processed with a fluorescent penetrant system there shall be no reflective surface, e. g. white paper on the inspection bench or in the immediate vicinity of the inspection area. In addition there shall be no stray white light sources near to the inspection area.

B.4.8 Compressed air filter(s)

Ensure that the trap(s) are free of contaminants.

B.4.9 Integrity of UV-A filters

Ensure that lamps with UV-A filters are in good condition.

B.4.10 UV-A irradiance

Measure UV-A irradiance as described in prEN ISO 3059.

B.4.11 Visible light intensity in inspection booth (fluorescent system)

Measure the maximum visible light intensity in the booth as described in prEN ISO 3059.

B.4.12 Visible light intensity (colour contrast systems)

Measure the minimum visible light intensity at working area as described in prEN ISO 3059.

B.4.13 Fluorescent intensity

B.4.13.1 Use standard reference samples of level 1 and 2 penetrants at 1 %, 0,9 %, 0,8 % in high flash kerosene. For level 3 penetrants use standard reference samples at 0,1 %, 0,09 %, 0,08 %. The reference samples shall be stored in light-proof sealed containers.

To prepare the reference samples it is suggested that dilutions of 10 %, 9 %, 8 %, are first prepared and then further diluted at 1 to 10 or 1 to 100 respectively.

B.4.13.2 For level 1 and 2 penetrants prepare a 1 % solution of the penetrant under test in the same solvent as used in B.4.13.1. For level 3 penetrants, prepare a 0,1 % solution of the penetrant under test in the same solvent as used in B.4.13.1.

B.4.13.3 Using test tubes, visually compare the fluorescent intensity of the penetrant under test against the reference samples of the same penetrant. UV-A illumination shall be evenly distributed with an irradiance of at least 10 W/m² (1000 μW/cm²).

Record the level to which the fluorescent intensities are similar.

As an alternative, the method described in 7.7 may be used.

Requirements: The fluorescent intensity shall be greater than 90% of the reference.

B.4.14 Colour contrast intensity

B.4.14.1 Use standard reference samples of the colour contrast penetrant at 1 %, 0,9 %, 0,8 % and 0,7 % in high flash kerosene or any other suitable non-volatile solvent.

To prepare the reference samples it is suggested that dilutions of 10 %, 9 %, 8 % and 7 % are first prepared and then further diluted at 1 to 10.

These reference samples shall be stored in light-proof sealed containers.

B.4.14.2 Prepare a 1 % solution of the penetrant under test in the same solvent as used in B.4.14.1.

B.4.14.3 Using test tubes, under evenly distributed visible light, compare the colour intensity of the penetrant under test against the reference samples.

Record the level to which the colour intensities are similar.

Requirement: Colour intensity shall be greater than 80 % of reference.

B.4.15 Suppliers' overcheck

A representative sample of the in-use penetrant shall be taken at least once a year and sent to the supplier's or other suitable laboratory for re-certification. Otherwise, the penetrant shall be discarded and replaced.

The overchecking laboratory shall issue a report stating that the physical-chemical parameters of the penetrant under test are all within acceptable limits when compared with the nominal values for a new penetrant. It is recommended that the report shows actual values and not only a statement.

It is the responsibility of the supplier to choose which parameters are to be checked.

B.4.16 Concentration of hydrophilic remover

The test is applicable for freshly prepared solutions and is carried out using a refractometer.

The test refractometer shall be calibrated using accurately prepared solutions of the new hydrophilic emulsifier. At least five solutions shall be used. One shall be the nominal concentration, two shall be above and two below the nominal concentration. The values shall be plotted graphically.

To estimate the concentration of the hydrophilic remover, read the value given by a sample of the freshly prepared product and determine its concentration from the graph.

All parts of the test shall be carried out at ambient temperature.

The results of this test shall be reported.

Requirements: Adjust concentration to required value. Mix well before rechecking.

NOTE This test is primary designed for freshly prepared solutions. It can however be used to adjust the concentration of in use tanks by the addition of either the emulsifier or water, but this determination can give inaccurate results.

B.4.17 Developers

B.4.17.1 Appearance of dry powder

Ensure that the powder is free from lumps and is friable.

The result of this test shall be reported.

B.4.17.2 Fluorescence of dry powder

Examine a sample of the powder under ultra-violet light to ensure that it is free from fluorescence.

The result of this test shall be reported.

B.4.17.3 Water soluble developer

B.4.17.3.1 Concentration

This test uses a graph of concentration against density produced by the manufacturer to determine the concentration of the developer.

- Check the level of the tank and bring it back to its original level by the addition of water and mix thoroughly.
- Take a sample of the contents of the tank and adjust the temperature to 20°C or to the temperature at which the hydrometer has been calibrated.
- Measure the density of the sample using a hydrometer.
- The density will enable the concentration of the developer to be determined from the graph.

The results of this test shall be reported.

B.4.17.3.2 Wetting test

Ensure that the whole surface of the reference test block type 2 used for the system performance check has been evenly coated with developer.

B.4.17.3.3 Temperature

Ensure that the developer temperature is within specified limits.

The result of this check shall be reported.

B.4.17.3.4 Fluorescence of solution

Examine a sample of the solution under ultraviolet light to ensure that it is free from fluorescence.

The result of this test shall be reported.

B.4.17.4 Water suspendible developer**B.4.17.4.1 Concentration**

This test uses a graph of concentration against density produced by the manufacturer to determine the concentration of the developer.

- Check the level of the tank and, if necessary, add water to bring it back to its original level and mix thoroughly to ensure a full and uniform suspension.
- Take a sample from the tank and adjust the temperature to 20°C or to the temperature at which the hydrometer has been calibrated.
- Measure the density of the sample using a hydrometer.
- The density will enable the concentration of the developer to be determined from the graph.

The result of this test shall be reported.

B.4.17.4.2 Temperature

Check that the developer temperature is within specified limits.

The results of this test shall be reported.

B.4.17.4.3 Fluorescence of suspension

Thoroughly agitate the bath of developer to ensure that the powder is in suspension. Examine a sample of the developer suspension under ultraviolet light to ensure that it is free from fluorescence.

The result of this test shall be reported.

B.4.18 Ultraviolet radiometer calibration

The in-use ultraviolet radiometer shall have valid calibration stickers or identification referring to prEN ISO 3059.

Before using the radiometer the operator shall check the stickers for the "valid to" or "calibrate before" dates. At least every 24 months the unit shall be calibrated.

The result of this test shall be reported.

B.4.19 Luxmeter calibration

The luxmeter shall have valid calibration stickers or identification referring to prEN ISO 3059.

Before using the luxmeter the operator shall check the stickers for the "valid to" or "calibrate before" dates. At least every 24 months the unit shall be calibrated.

The result of this test shall be reported.

B.4.20 Thermometer calibration

Check that all thermometers have valid calibration identification.

The result of this test shall be reported.

The thermometers can be calibrated in house by first placing them in thawing ice (0°C) and then in boiling water (100°C).

B.4.21 Pressure gauges calibration

Check that all gauges are set within the nominal values stated by the applicable process procedure. Check that they have valid calibration identification. The result of this test shall be reported.

Annex C

(informative)

Determination of fluorescent penetrant sensitivity levels

A variety of methods for determining sensitivity levels have been used in the past. In most cases, however, they have been dependent upon unique test specimens and/or measuring equipment. This makes independent verification of sensitivity levels virtually impossible to perform. Additionally, most traditional methods, based sensitivity levels directly or indirectly on the quantity of fluorescent material in the penetrant, i. e. the assumption was made in these cases that fluorescent brightness is an indicator of sensitivity. In reality, whilst fluorescent brightness is one major factor in penetrant sensitivity, tests have shown that the probability of detection of a discontinuity is also dependent upon whether a penetrant stays in a discontinuity and, if so, how reproducible it is.

This specification sets out to address these issues by using a method for determining sensitivity that:

- is reproducibly verifiable by an independent suitably equipped laboratory;
- takes into account both fluorescent brightness and reproducibility of results to give a higher measure of probability of detection.

EXAMPLE The two traces reproduced in figure C.1 have both been obtained by the method detailed in section 7.2 of this standard. Both have similar average brightness of indications and, so would be labelled as equivalent sensitivity by some test methods. However, the variability of trace 2 is much greater than that of trace 1. This means that the penetrant used to give trace 2 could be less likely to detect a specific discontinuity due to the wide variance in discontinuity brightness. For this reason, by this method, penetrant 2 would be designated a lower sensitivity than penetrant 1.

The method detailed in 7.2 uses standard deviation as a measure of reproducibility, and hence differentiates between the products in terms of sensitivity.

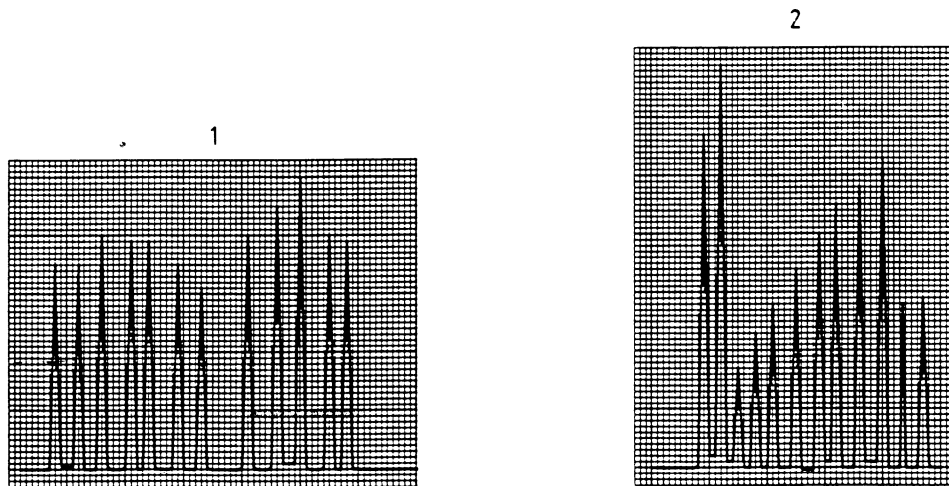
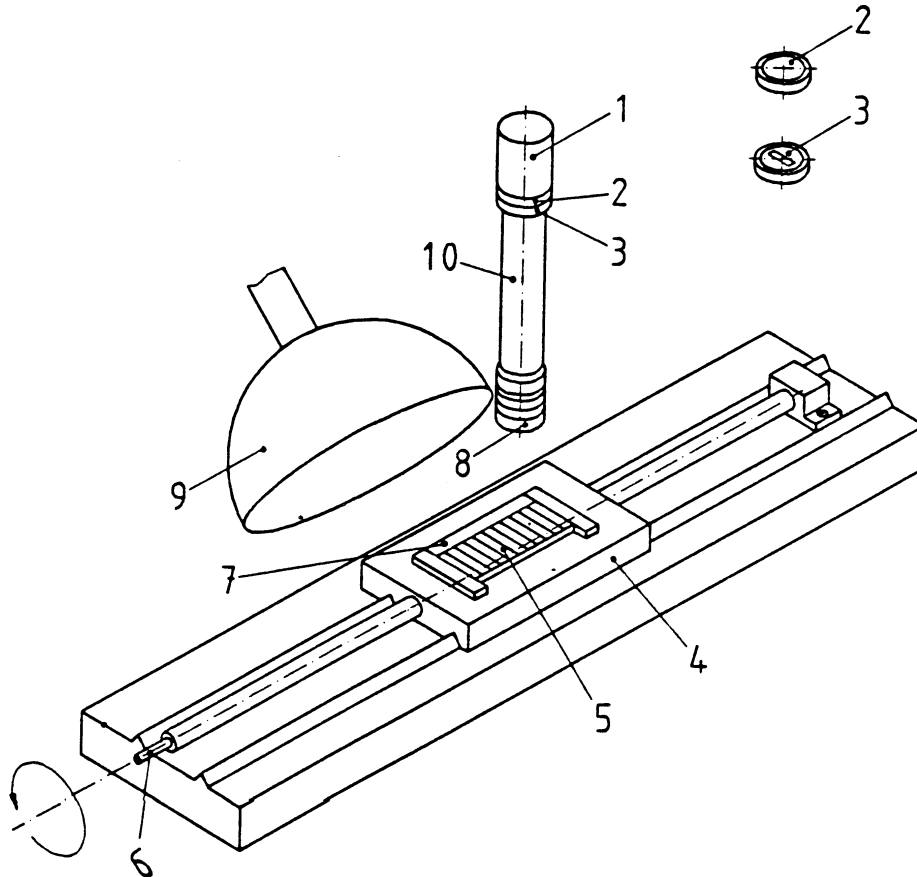

Figure C.1 - Two examples of traces from a discontinuity intensity measuring equipment

Annex D
(informative)**Example of indication visibility measuring equipment****D.1 General configuration**

The microscope assembly is fixed in a vertical position above the test panel holder and moving table such that the test panel holder containing a test panel from reference block type 1 or instrument calibration standard can be moved at reproducible and constant speed under the microscope assembly and at right angles to the slot direction. The chart recorder is connected directly to the photo-multiplier tube. The source of UV-A radiation is positioned in close proximity to the test panels.



- 1 Photomultiplier tube, output to recording system
- 2 Optical filter
- 3 Blanking plate
- 4 Moving table
- 5 Test panel
- 6 Constant speed drive
- 7 Test panel holder
- 8 Photographic lens
- 9 UV-A source
- 10 Microscope tube

Figure D.1 - Indication visibility measuring equipment (example)

D.2 Microscope assembly

The microscope assembly consists of a simple microscope tube with a photographic lens at one end and a photomultiplier tube at the other end. Between the lens and the photomultiplier are a blanking plate and an optical filter. The blanking plate has an aperture to ensure that the photomultiplier receives the emitted light from only one discontinuity on the test panel, at the same time. The optical filter transmits visible light of $550 \text{ nm} \pm 25 \text{ nm}$.

D.3 Test panel holder and moving table

The test panel holder consists of a flat table capable of clamping an individual test panel in a reproducible and identical position. The test panel holder is mounted on to a motor-driven moving table which drives the holder backwards and forwards at approximate 25 mm/min.

D.4 Recording system

The recording system consists of a chart recorder or equivalent computer data collection system the input of which is supplied by the output from the photomultiplier tube.

The photomultiplier tube and chart recorder specifications is such that when illuminated in accordance with D.5 the standard calibration test piece produces a peak on the recorder with a height of $50 \% \pm 5 \%$ of a full scale deflection.

D.5 Illumination

The test panel or calibration test piece is illuminated over the area being viewed by the optical system with an UV-A level of 10 W/m^2 to 20 W/m^2 ($1000 \mu\text{W/cm}^2$ to $2000 \mu\text{W/cm}^2$) and a visible light level below 10 lux. Illumination levels on the test panel should not be altered during the test.

BSI — British Standards Institution

BSI is the independent national body responsible for preparing British Standards. It presents the UK view on standards in Europe and at the international level. It is incorporated by Royal Charter.

Revisions

British Standards are updated by amendment or revision. Users of British Standards should make sure that they possess the latest amendments or editions.

It is the constant aim of BSI to improve the quality of our products and services. We would be grateful if anyone finding an inaccuracy or ambiguity while using this British Standard would inform the Secretary of the technical committee responsible, the identity of which can be found on the inside front cover. Tel: 020 8996 9000. Fax: 020 8996 7400.

BSI offers members an individual updating service called PLUS which ensures that subscribers automatically receive the latest editions of standards.

Buying standards

Orders for all BSI, international and foreign standards publications should be addressed to Customer Services. Tel: 020 8996 9001. Fax: 020 8996 7001.

In response to orders for international standards, it is BSI policy to supply the BSI implementation of those that have been published as British Standards, unless otherwise requested.

Information on standards

BSI provides a wide range of information on national, European and international standards through its Library and its Technical Help to Exporters Service. Various BSI electronic information services are also available which give details on all its products and services. Contact the Information Centre. Tel: 020 8996 7111. Fax: 020 8996 7048.

Subscribing members of BSI are kept up to date with standards developments and receive substantial discounts on the purchase price of standards. For details of these and other benefits contact Membership Administration. Tel: 020 8996 7002. Fax: 020 8996 7001.

Copyright

Copyright subsists in all BSI publications. BSI also holds the copyright, in the UK, of the publications of the international standardization bodies. Except as permitted under the Copyright, Designs and Patents Act 1988 no extract may be reproduced, stored in a retrieval system or transmitted in any form or by any means – electronic, photocopying, recording or otherwise – without prior written permission from BSI.

This does not preclude the free use, in the course of implementing the standard, of necessary details such as symbols, and size, type or grade designations. If these details are to be used for any other purpose than implementation then the prior written permission of BSI must be obtained.

If permission is granted, the terms may include royalty payments or a licensing agreement. Details and advice can be obtained from the Copyright Manager. Tel: 020 8996 7070.